

REV.	ECN NO.	REVISIONS	DRN.	CKD.	APP.	DATE
A		NEW RELEASE	ADM			

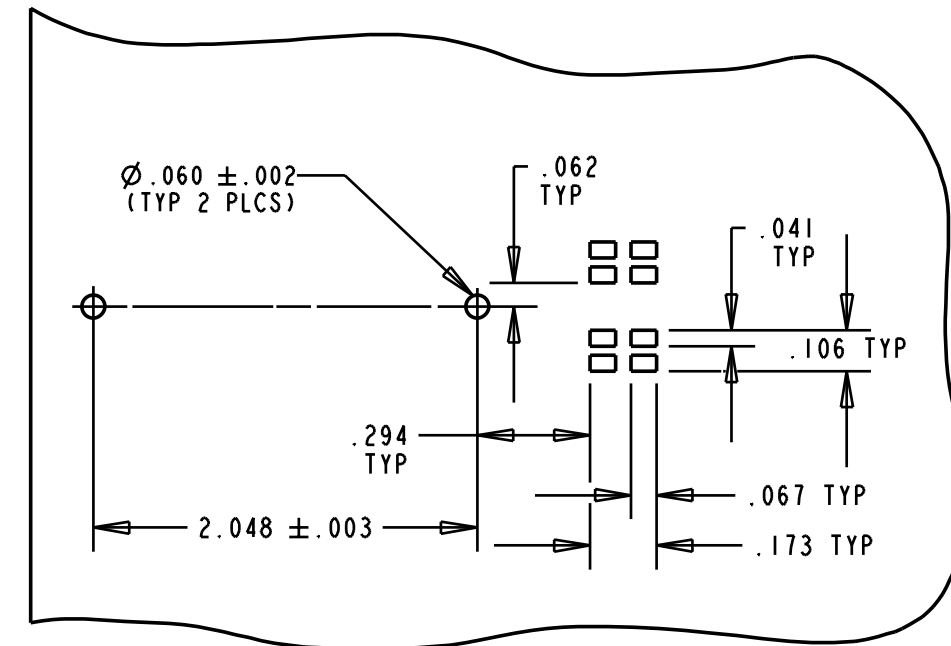

SOLDER PAD/HOLES LAYOUT
SCALE: 2:0

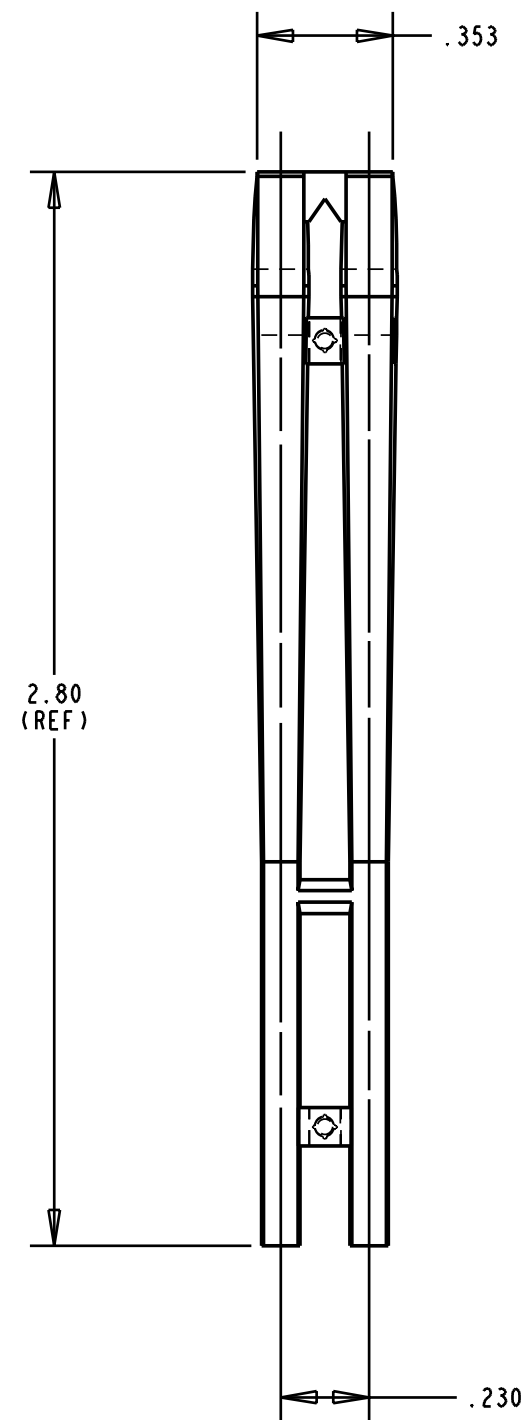
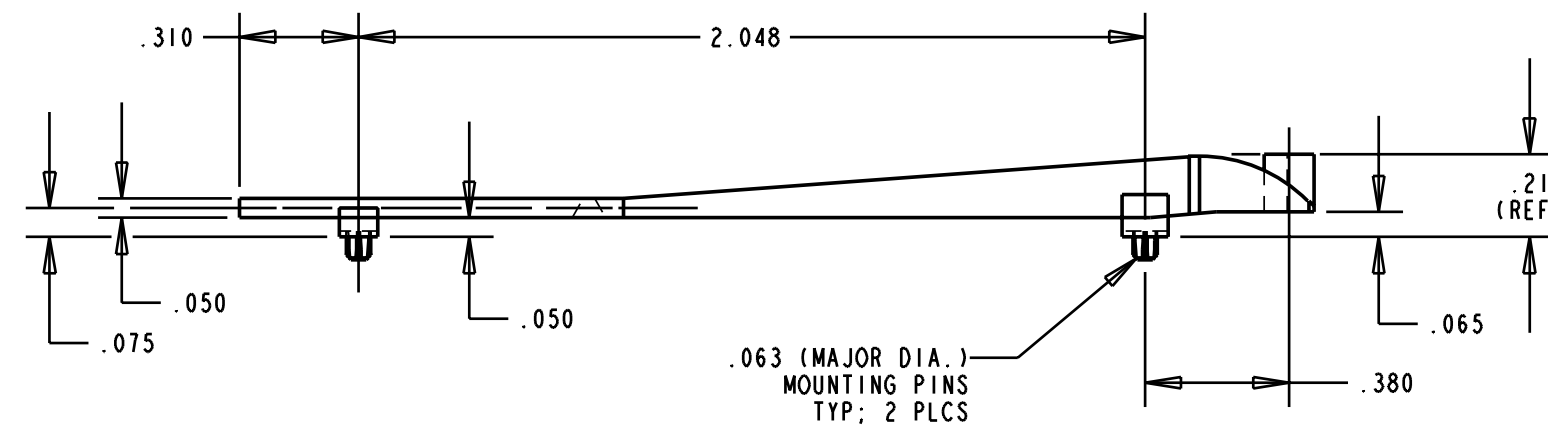
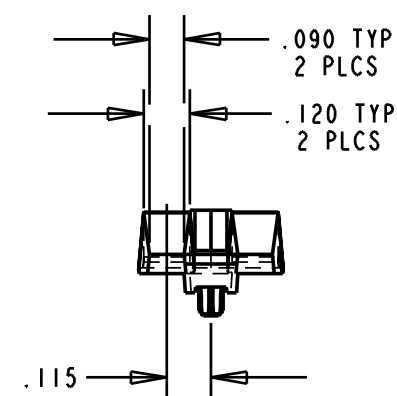
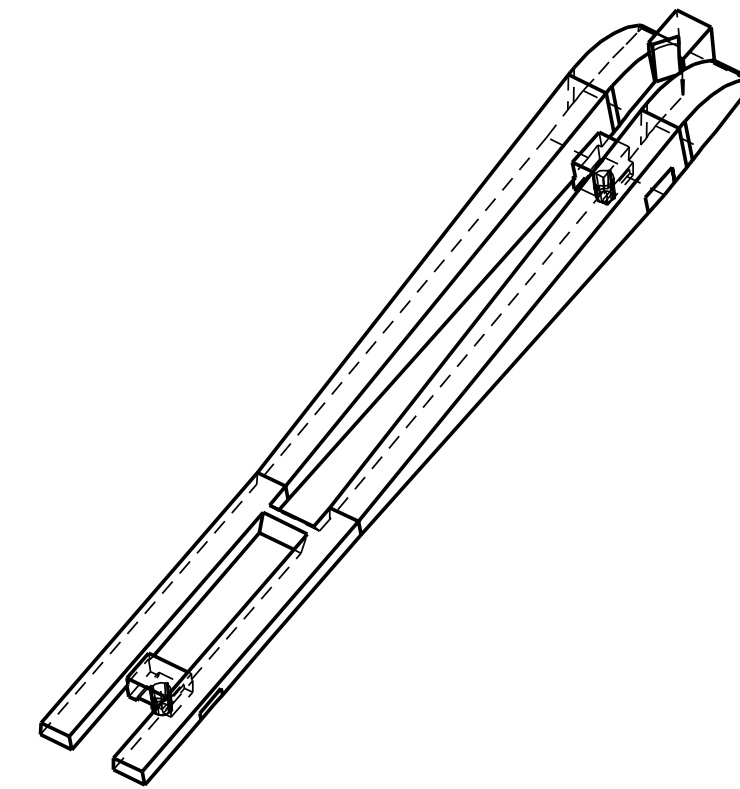

- NOTES: 1
1. COMPONENT TO BE MOLDED IN A CLEAR TRANSMISSIVE POLYCARBONATE.)
2. COMPONENT DESIGNED TO BE PRESSED INTO A P.C. BOARD.)
3. LIGHTSOURCE: RED/GREEN SMT BI-COLOR LED (DIALIGHT P/N: 597-7701-5XX).)
4. DIALIGHT PART NUMBER: 515-1110.

THIS DRAWING AND THE CONTENTS HEREIN ARE CONFIDENTIAL AND THE SOLE PROPERTY OF DIALIGHT. REPRODUCTION OF THIS DRAWING OR CONSTRUCTION OF ANY PARTS WITHIN THIS DRAWING ARE FORBIDDEN WITHOUT THE WRITTEN CONSENT OF DIALIGHT.		
SCALE 2:0	DRAWING NUMBER	REV
ALL DIM'S IN: INCHES	C-16808	A
TOLERANCES: UNLESS OTHERWISE SPECIFIED	TITLE	
FRACTIONS: ±1/64	2 ELEMENT LIGHTPIPE	
DECIMALS (.XX): ±.02	MATERIAL	
DECIMALS (.XXX): ±.015	Dialight	
DECIMALS (.XXXX): ±.0005	1501 ROUTE 34 SOUTH	
ANGLES: ±1°	FARMINGDALE, NJ 07727	
FINISH:	FSCM 83330	SHEET OF FAMILY TABLES: